

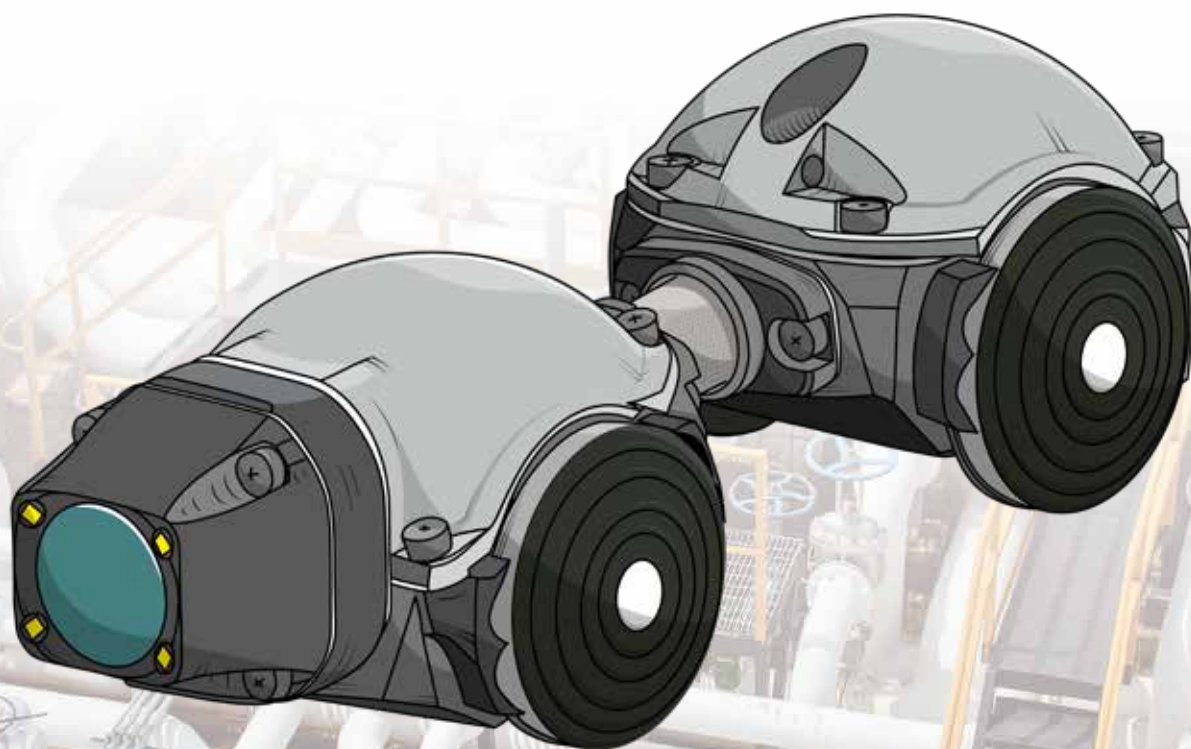

IPIDRO



IPIDRO

Magnetic Inspection Crawler for hard-to-reach Areas

Compact **All-in-One** Solution with an Impressive Total Weight of Just **18 kg***

More than **8 Hours** of Inspection Time with a Standard Professional-Grade Battery

The most **Ergonomic** Control Unit on the Market, featuring IP64 Protection and an **Aluminum-Carbon Fiber** Housing for Maximum User Comfort

Advanced **Dual-Touch** Interface with **Joysticks, Buttons, and Scroll Wheels** for Professional Control

10.1" IPS-TFT Display with **Full-HD+** and **1920 x 1200** Pixels for Outstanding, **Uncompressed Image Quality**



Magnetic Wheels with reinforced polyurethane coating for **Maximum Traction**. Even upside down and with an additional payload of 200 g**

Anodized and **Heat-optimized Aluminum Housing** with a diameter of just **Ø 48 mm | 1.89 in**

Intuitively Designed **Camera Control Icons** Placed **Outside the Inspection Image** Ensure an Unobstructed View and Maximum Operating Efficiency

Motorized **Remote Focus**, adjustable from (20 mm to ∞) for high-definition results at the tip of your fingers

Fixed front-view camera with **Wide-Angle Lens** and **Uncompressed Full-HD** resolution (1920 x 1080p)

*Depending on configuration

**Depending on material and application conditions



RESOLUTION

Fixed front-view camera (DOV 0°) with a **145° wide-angle lens** delivers uncompressed **Full HD resolution** (1920 × 1080p) for detailed image acquisition.



DESIGN

With a compact **48 mm diameter**, the IPIDRO delivers **unbeatable accessibility** and thanks to a flexible connector, also suitable for navigating steep inclines.

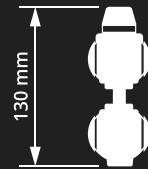

COMPACT

Measuring just **130 mm in length**, the IPIDRO is **exceptionally compact** and can easily be deployed in confined spaces with tight entry points.



TRACTION

Magnetic wheels with reinforced polyurethane coating and differential steering for **maximum traction** on ferromagnetic surfaces. Reliable inspections even upside down.



ALUMINIUM

Anodized, **heat-optimized aluminum** housing ensures low weight and **minimizes surface contamination**.



SPEED

With a constant **travel speed** of up to **3 m/min**, the IPIDRO quickly and accurately positions itself at the inspection site for efficient operation.



BATTERY OPERATION

Up to **8 hours** of mobile work with standard professional grade batteries and **UNINTERRUPTED power transition** between battery and mains.

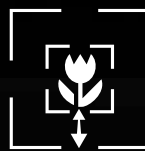

REMOTE FOCUS

Motorized remote focus, proven in the VUMAN video-scope. Adjustable from **20 mm to infinity** for high-definition results.

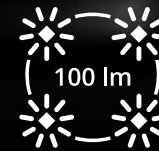

ILLUMINATION

Four **dimnable white LED** channels provide up to **100 lumens** for adjustable illumination intensity.





REMOTE VISUAL INSPECTION

REIMAGINED

Experience a turning point in remote visual inspection. The IPIDRO redefines efficiency and repeatability for inspections in hard-to-reach areas. As a true gamechanger in RVI, the IPIDRO replaces traditional push rods and rigid equipment with a modern approach that delivers spectacular results from a distance. Initially engineered for steam header/steam manifolds, the IPIDRO gives you the freedom to inspect pipelines, boilers and other ferromagnetic structures with speed, confidence, and unmatched manoeuvrability. A quantum leap for modern inspections workflows.

PHENOMINAL TRACTION

IN FERROMAGNETIC ENVIRONMENTS

Magnetic wheels with reinforced polyurethane coating, combined with differential steering and all-wheel drive, provide maximum grip on ferromagnetic surfaces, even allowing for reliable overhead or inverted inspections. The flexible connector further enhances the IPIDRO's adaptability, enabling smooth navigation on steep inclines. The IPIDRO travels swiftly along inspection paths, reaching target areas at speeds up to 3 m/min.

EXCEPTIONAL IMAGING

WITHOUT COMPROMISE



At the heart of the IPIDRO is a fixed, front-facing camera equipped with a 145° wide-angle lens, delivering uncompressed Full HD resolution at 1920 × 1080 pixels. Whether you're facing low-light conditions, tight corners, or obstructed areas, the motorized remote focus allows precision adjustments from 20 mm to infinity at the press of a button. This allows every inspection to deliver high-definition results without compromising on quality. Four dimmable high-performance LEDs illuminate dark environments, achieving exceptional image clarity thanks to a light sensitivity down to 0.003 lux which equals to several meters/yards of visibility.

INDUSTRY READY

BUILT FOR PROFESSIONAL DEMANDS

The IPIDRO redefines the standards of remote visual inspection by delivering reliable results even in the most demanding industrial environments. Its versatility extends across a wide range of applications, including metallic pipelines, heat exchangers, cooling lines, process pipes, HVAC air ducts, boilers, pressure vessels and silos. Whether navigating tight bends or scaling vertical shafts, the IPIDRO's compact design and all-wheel drive system ensure fast, repeatable inspections with minimal effort.



Designed for critical infrastructure, such as chemical plants, oil and gas installations, refineries, power generation facilities, and utility networks, the IPIDRO provides dependable performance where reliability is essential.

With its advanced imaging system, it enables the early detection of corrosion, leaks, deposits, and obstructions, supporting proactive, condition-based maintenance while enhancing operational integrity.

With these purpose-engineered features, the IPIDRO transforms both routine and specialized inspections into streamlined, repeatable processes for industrial professionals.

vunit

FULL-HD CONTROL UNIT WITH INTEGRATED VIDEO DOCUMENTATION

- 1 Aluminum-Carbon Composite: Lightweight yet Highly Durable
- 2 Scroll Wheel for Quick Adjustments
- 3 Intuitive Joystick Control for Easy Camera Head Movement
- 4 Direct-Access Buttons
- 5 Capacitive Dual-Touchscreen, fully Operable with Protective Gloves (PPE)
- 6 External Storage Options: USB + SD Card
- 7 HDMI Output for Uncompressed Image Output



High-Resolution Display

- 10,1" IPS-TFT-Panel
- Display Resolution: 1920 × 1200 px
- Native Full-HD Inspection Image: 1920 × 1080 px
- 16.7 Million Colors
- Brightness: 850 cd/m² (850 nits)
- User-Friendly Interface with intuitive Icon Navigation, Direct-Access Buttons, Joysticks, and Scroll Wheels

Ergonomic Design

- Compact, ergonomic Grip Design
- Ideally positioned Joysticks for Fatigue-Free Operation
- Ultra-Light Housing made from Aluminum-Carbon Composite

ADAPTIVE OPERATION

FOR MAXIMUM FLEXIBILITY

The VUnit sets new standards in adaptability and user comfort. Whether positioned on a tabletop, securely mounted for hands-free use or worn with a neck strap, it adapts effortlessly to the needs of the operator. It can also be controlled directly from the VUcase, making it especially practical for mobile inspections.

For improved ergonomics, the VUnit can even be suspended to provide a clear and comfortable viewing position. This adaptability supports smooth operation across all inspection environments, regardless of on-site challenges.



MODULAR DESIGN

QUICK REPLACEMENTS EASY MAINTENANCE

The VUnit is divided into five independent modules, each of which can be quickly and easily replaced when needed. This modular concept simplifies maintenance, speeds up repairs, and significantly reduces downtime and service costs.

Its user-friendly design allows components to be replaced on-site without the need for special tools or technical support. This keeps the VUnit fully operational and ready to adapt to evolving inspection demands.



VUapp

DEVELOPED BY INSPECTORS FOR INSPECTORS

The VUapp is a purpose-built software solution, designed specifically to meet the demands of professional inspection workflows. It combines a powerful architecture with an intuitive user interface, enabling Full-HD video recording and lossless PNG image capture with exceptional quality.

With its DualCapture technology, the VUapp allows simultaneous video recording and still image capture, without any loss in quality. The integrated text generator with comment function makes it easy to overlay key system data, pressure values or camera positions directly onto recordings.

Even with large volumes of data, the advanced metadata search function enables fast and targeted retrieval of inspection results.

Software updates can be installed effortlessly on-site via flash drive, keeping your system up to date without the need for time-consuming shipping or service appointments.



UNCOMPRESSED VIDEO OUTPUT

STREAMLINED AI INTEGRATION

The VUnit's integrated HDMI output delivers uncompressed inspection imagery, free from disruptive graphical overlays, ready for direct integration into existing AI systems.

With an impressive action-to-image latency of just 120 ms, reliable real-time analysis is ensured. Its open interface enables fluid integration of customer-specific AI applications, supporting automated inspection workflows, reduced processing times, and efficient downstream data handling.



Moreover, the HDMI interface promotes cross-location collaboration:

Inspection results can be captured on-site and simultaneously shared and analyzed in real time with remote team members. This not only cuts travel costs but also enhances decision-making and significantly improves process reliability.

VUcase

TRANSPORT CASE WITH INTEGRATED VIDEO INTERFACE

The VUcase is the ideal interface for the INVIZx98 and the VUnit, combining exceptional functionality, flexibility, and durability in one smart, field-ready design. Its built-in video interface and versatile power options enable professional-grade operation in any environment.

The system can be powered via mains or high-capacity professional-grade lithium-ion batteries, offering up to 8 hours of continuous use. A seamless switch between power sources during operation allows uninterrupted inspections.

The VUcase also provides generous storage space for the inspection module, connection cables, VUnit, and accessories. With IP53 protection in horizontal position and the ability to operate the system even with the lid closed, the VUcase proves exceptionally resilient, even under challenging weather conditions.



DYNAMIC VIDEO TRANSMISSION & CUSTOM INTEGRATION

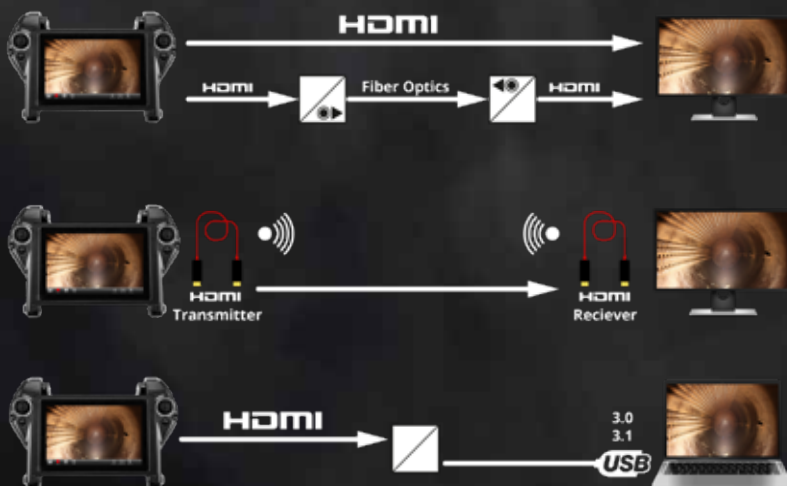

The VUnit's standardized HDMI interface enables straightforward and commercially proven solutions for both wired and wireless video transmission.

The three most common methods are illustrated in the adjacent graphics.

Ask us about simple integration of these transmission options into the VUcase housing.







For connecting to your IT systems (e.g., a laptop), we recommend using a commercially available HDMI-to-UVC converter (minimum USB 3.0).

This approach keeps cybersecurity fully under your organization's control.



FULL-HD INSPECTION MODULES	IPIDRO	INVIZx98 Ti 45	INVIZx98 AI 45
Type	1/3" Sony CMOS Sensor	1/3" Sony CMOS Sensor	1/3" Sony CMOS Sensor
Resolution	1920(H) x 1080(V)	1920(H) x 1080(V)	1920(H) x 1080(V)
Zoom	-	10x Optical Zoom	10x Optical Zoom
Focus Range	20 mm up to ∞	10 mm 0.39 in	10 mm 0.39 in
Light Sensitivity	0,003 lx	Color 0,125 lx	Color 0,125 lx
Shutter Speed	1/30(25) bis 1/30,000 sec	1/30(25) bis 1/30,000 sec	1/30(25) bis 1/30,000 sec
Camera Temperature Display	No	Yes	Yes
Cable Length	20 m	3 m, 30 m, 50 m and optionally up to 80 m, wound on the viZaar® cable reel VUreel	3 m, 30 m, 50 m and optionally up to 80 m, wound on the viZaar® cable reel VUreel
FOV	145°	68° - 6,8°	68° - 6,8°
Image Enhancement Features:	Wide Dynamic Range & Advanced Noise Reduction	Wide Dynamic Range & Advanced Noise Reduction	Wide Dynamic Range & Advanced Noise Reduction
ILLUMINATION			
Light Source	4 dimmable LEDs	2 x 1000 lumen Dual wide-angle LEDs	2 x 1000 lumen Dual wide-angle LEDs
OPERATING ENVIRONMENT			
Temperature Range	-10°C to +45°C (14°F to 113°F)	0°C to +48°C (32°F to 118.4°F)	0°C to +48°C (32°F to 118.4°F)
Pressure Resistance:	-	4.5 bar (≈ 65 psi)	4.5 bar (≈ 65 psi)
Internal Housing Overpressure:	-	Max. 2 bar (≈ 29 psi)	Max. 2 bar (≈ 29 psi)
PAN AND TILT RANGE			
Pan Range:	-	360° continuous rotation	360° continuous rotation
Tilt Range:	-	330° - from -165° to +165°	330° - from -165° to +165°
Axis Speed:	-	Full 360° rotation in under 4 seconds	Full 360° rotation in under 4 seconds
DIMENSIONS			
Weight:	1000 g with umbilical cable	1900 g 4.19 lb	1400 g 3.08 lb
Dimensions (mm):	Ø 48 mm 1.89 inch - Length: 130 mm 5.11 inch	Width: 97.8 mm 3.85 in Height: 135 mm 5.3 in	Width: 97.8 mm 3.85 in Height: 135 mm 5.3 in
Accessory Mounting:	-	M6 mounting points	M6 mounting points
Housing:	Black anodized aluminum	Corrosion-resistant grade 5 titanium housing	Combination of red anodized and hard-anodized aluminum

ACCESSORIES FOR FULL-HD INSPECTION MODULES

<p>Accessory Box</p>	<ul style="list-style-type: none"> • Adapter for strain relief, carbon poles, push poles and compressed air • Strain relief • Special tools for assembly 	
<p>Optional Batteries incl. charging system</p>	<ul style="list-style-type: none"> • Stihl Battery AP 200 S • Stihl Battery AP 300 S • Stihl Battery AP 500 S 	
<p>Pneumatic Handpump</p>	<p>For pre-pressure adjustment and continuous pressure monitoring</p>	
<p>Carbon Poles</p>	<p>Used for mounting and guiding the camera head inside the test object; extendable and available in 1 m and 2 m lengths.</p>	
<p>Cable Strain Relief</p>	<p>Protects cable connections from tensile forces when removing the camera head; essential when the camera is used in a suspended position.</p>	
<p>Commercially available accessories tested and recommended for operation with the VUnit</p>	<ol style="list-style-type: none"> 1. USB drive with hardware security: User-friendly stick with military-grade security architecture for reliable protection of sensitive inspection data. 2. Streaming solution for real-time applications: Plug-and-play system for true-color, latency-free transmission of the inspection image for AI applications or collaboration with remote teams. 	
<p>Manhole Tripod</p>	<p>Simplifies the inspection of containers / chambers through targeted guidance / mounting</p>	



www.vizaar.com



For more
information

IPIDRO

XPANDING YOUR **VU**[®]
IN *FULL HD*



Headquarter

Hechinger Straße 152
72461 Albstadt / Germany
Fon.: +49 7432 98375-0
Fax: +49 7432 98375-50
Freecall 0800 3600371
(only within Germany)
info@vizaar.com

VT Service / Rental Service / Sales / Training Center

Lupusstraße 17
35789 Weilmünster / Germany
Fon.: +49 6475 91129-0
Fax: +49 6475 91129-29

viZaar North Germany

VT Service / Rental Service / Sales
29339 Wathlingen / Germany
Fon.: +49 160 93777644
Fax: +49 6475 91129-29

OUR SERVICE AND SALES OFFICES

viZaar NRW

Sales and Service Office

46348 Raesfeld / Germany
Fon.: +49 170 5703130

viZaar Maritime

Sales and Service Office

25361 Krempe / Germany
Fon.: +49 171 5524094

viZaar South

Sales and Service Office

88161 Lindenberg in Allgäu / Germany
Ton.: +49 172 6019601



viZaar industrial imaging SA

3 rue Lambert
Parc Lavoisier
91410 Dourdan / France
Fon.: +33 1608 11818
Fax: +33 1645 99573
www.vizaar.fr
info@vizaar.fr

Authorized trade and distribution partner of viZaar®: